

**NOTICE OF CONSIDERATION OF ORDINANCE
TO VACATE TO THE OWNERS OF 215 BARRINGTON AVE. THE TWELVE FOOT
WIDE RIGHT-OF-WAY LOCATED SOUTH OF 215 BARRINGTON AVE., EAST
DUNDEE, ILLINOIS**

At the Village of East Dundee Board of Trustees meeting to be held on Monday, October 15, 2018 at 6:00 P.M. at the Second Floor of the Village of East Dundee Police Department at 115 E. 3rd Street, East Dundee, Illinois, the Village President and Board of Trustees of the Village of East Dundee will consider an ordinance relative to a request to vacate the twelve foot wide right-of-way immediately adjacent to the south side of property located at 215 Barrington Ave, East Dundee, Illinois ("ROW Parcel"), and convey title to the ROW Parcel to the owners of the 215 Barrington Ave. property (P.I.N.: 03-23-303-011). A request to vacate and convey title to the ROW Parcel has been submitted to the Village by Kathleen Bergeron, NEXT TREASURE LLC, owner of 215 Barrington Ave. (collectively the "Property Owners").

At the October 15, 2018 Village Board meeting, the Property Owners, any interested party and the public are free to comment to the Village Board on the request of the Property Owners to vacate solely to them the ROW Parcel. The Village Board will then consider whether to adopt an Ordinance vacating the ROW Parcel to the Property Owners. Consideration by the Village Board of the request to vacate the ROW Parcel is pursuant to the Illinois Municipal Code vacation provisions, 65 ILCS 5/11-91-1, *et seq.*

If you would like to comment on this proposed vacation, you are welcome to attend the above-mentioned Village Board meeting or you may submit written comments to the Village Administrator at 120 Barrington Avenue, East Dundee, Illinois 60118.

PLAT OF VACATION

OF

OF PART OF BARRINGTON AVENUE, IN THE VILLAGE OF EAST DUNDEE,
KANE COUNTY, ILLINOIS.

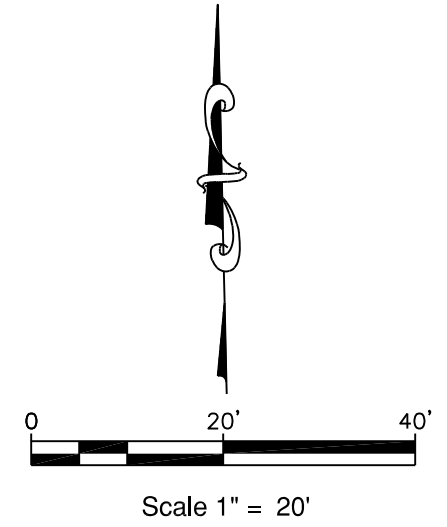
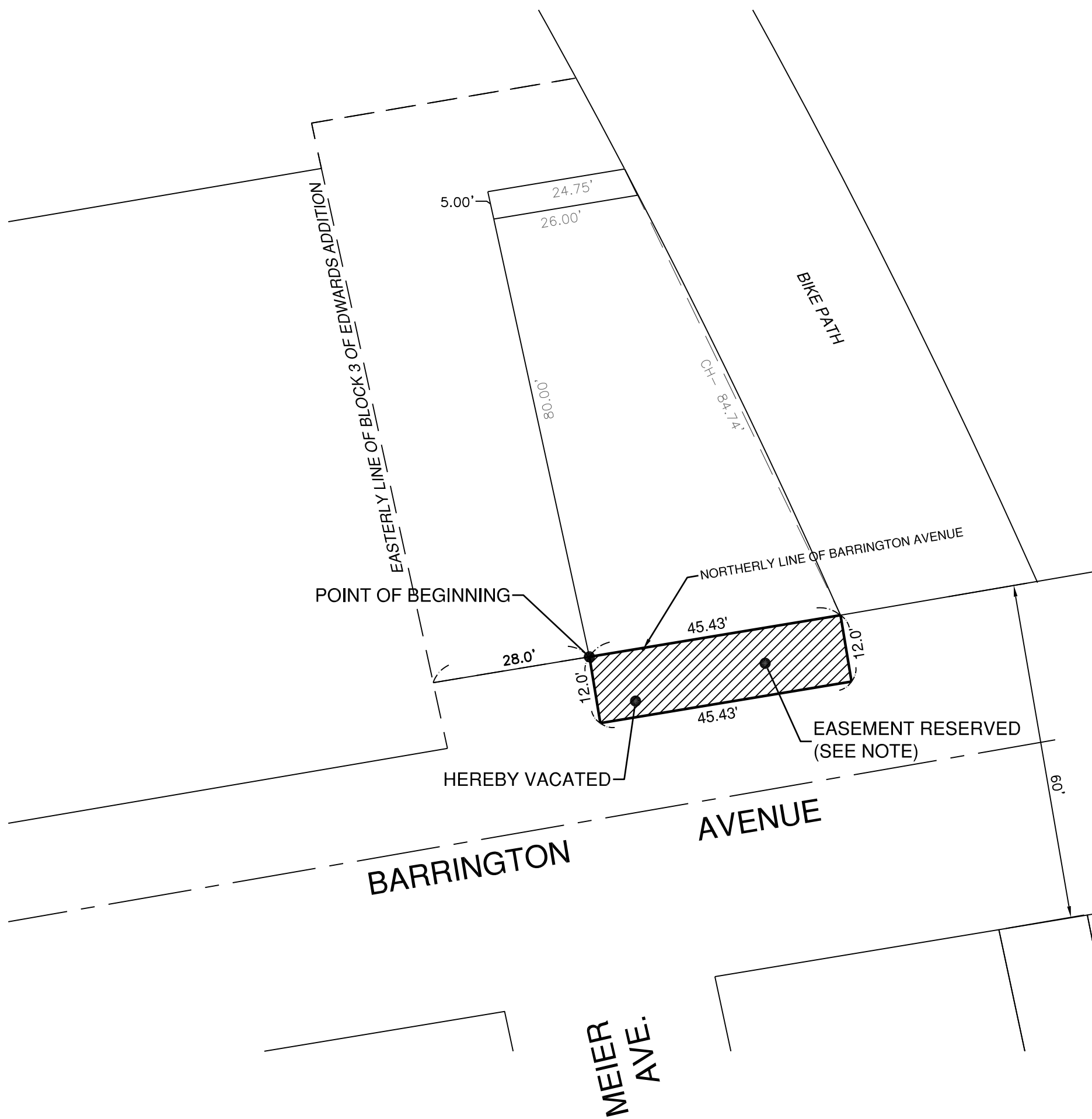

LEGAL DESCRIPTION FOR BARRINGTON AVENUE RIGHT-OF-WAY VACATION WITH RESERVATION OF EASEMENT:

THAT PART OF BARRINGTON AVENUE IN THE SOUTHWEST QUARTER OF SECTION 23, TOWNSHIP 42 NORTH, RANGE 8 EAST OF THE THIRD PRINCIPAL MERIDIAN, BOUNDED AND DESCRIBED AS FOLLOWS: BEGINNING AT THE INTERSECTION OF THE NORTHERLY LINE OF BARRINGTON AVENUE AND A LINE 28 FEET EAST OF (AS MEASURED ALONG THE NORTHERLY LINE OF BARRINGTON AVENUE) AND PARALLEL WITH THE EASTERLY LINE OF BLOCK 3 OF EDWARDS ADDITION TO THE VILLAGE OF EAST DUNDEE; THENCE EASTERLY ALONG THE NORTHERLY LINE OF SAID BARRINGTON AVENUE, 45.43 FEET; THENCE SOUTHERLY, PERPENDICULAR TO THE LAST DESCRIBED LINE, FOR A DISTANCE OF 12.0 FEET; THENCE WESTERLY, PARALLEL TO AND 12.0 FEET DISTANCE FROM THE NORTHERLY LINE OF SAID BARRINGTON AVENUE, FOR A DISTANCE OF 45.43 FEET; THENCE NORTHERLY, PERPENDICULAR TO THE LAST DESCRIBED LINE, FOR A DISTANCE OF 12.0 FEET, TO THE POINT OF BEGINNING, IN THE VILLAGE OF EAST DUNDEE, KANE COUNTY, ILLINOIS.

CONTAINING 0.013 ACRES MORE OR LESS.

NOTE:
THE VILLAGE OF EAST DUNDEE, COOK AND KANE COUNTIES, ILLINOIS HEREBY RESERVES AN EASEMENT OVER, UNDER, ACROSS, ALONG, AND UPON THE SURFACE OF THE VACATED RIGHT OF WAY TO INSTALL, OPERATE, MAINTAIN AND REMOVE FROM TIME TO TIME ABOVE GROUND AND UNDERGROUND FACILITIES AND APPURTENANCES USED IN CONNECTION WITH WATER, SANITARY SEWER OR STORM DRAINAGE SYSTEMS OF THE VILLAGE, AND ANY OTHER PUBLIC UTILITIES EXPRESSLY PERMITTED BY THE VILLAGE.

COUNTY CLERK'S CERTIFICATE

STATE OF ILLINOIS }
COUNTY OF KANE } SS.

I, _____, COUNTY CLERK OF KANE COUNTY, ILLINOIS, DO HEREBY CERTIFY THAT THERE ARE NO DELINQUENT GENERAL TAXES, NO UNPAID FORFEITED TAXES, AND NO REDEEMABLE TAX SALES AGAINST ANY OF THE LAND INCLUDED IN THE PLAT HEREIN DRAWN. I FURTHER CERTIFY THAT I HAVE RECEIVED ALL STATUTORY FEES IN CONNECTION WITH THE PLAT HEREIN DRAWN.

GIVEN UNDER MY HAND AND SEAL AT GENEVA, KANE COUNTY, ILLINOIS, THIS ____ DAY OF _____ AD., 2018.

COUNTY CLERK

KANE COUNTY RECORDER'S CERTIFICATE

STATE OF ILLINOIS }
COUNTY OF KANE } SS.

THIS INSTRUMENT NO. _____ WAS FILED FOR RECORD IN THE RECORDER'S OFFICE OF KANE COUNTY, ILLINOIS, ON THE ____ DAY OF _____, A.D., 20 ____ AT ____ O'CLOCK, __.M.

COUNTY RECORDER

CERTIFICATE OF VACATION APPROVAL

STATE OF ILLINOIS }
COUNTY OF KANE } SS.

THIS PLAT OF VACATION WITH RESERVATION OF EASEMENT HAS BEEN APPROVED BY THE VILLAGE BOARD OF TRUSTEES OF THE VILLAGE OF EAST DUNDEE, ILLINOIS AT A MEETING HELD ON THIS ____ DAY OF _____, A.D., 20 ____.

VILLAGE PRESIDENT

VILLAGE CLERK

SURVEYOR'S CERTIFICATE

STATE OF ILLINOIS }
COUNTY OF KANE } SS.

I, JOSEPH D. HEINZ, ILLINOIS PROFESSIONAL LAND SURVEYOR NO. 3551, DO HEREBY CERTIFY THAT I HAVE SURVEYED THE ABOVE DESCRIBED PROPERTY AND THAT THE PLAT HEREON DRAWN CORRECTLY REPRESENTS SAID SURVEY.

DATED AT EAST DUNDEE, ILLINOIS
THIS 27TH DAY OF SEPTEMBER, 2018 A.D.

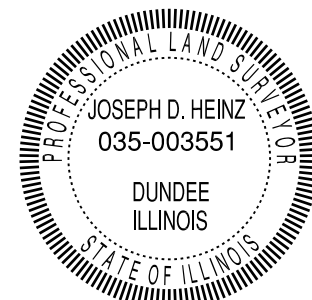

ILLINOIS PROFESSIONAL LAND SURVEYOR NO. 3551
LICENSE EXPIRES 11-30-20
DESIGN FIRM REGISTRATION NO. 184-002048

GERALD L. HEINZ & ASSOCIATES, INC.
CONSULTING ENGINEERS & LAND SURVEYORS
206 NORTH RIVER STREET
EAST DUNDEE, ILLINOIS 60118

PLAT OF VACATION
215 BARRINGTON AVE
EAST DUNDEE, ILLINOIS

VILLAGE OF EAST DUNDEE
120 BARRINGTON AVE
EAST DUNDEE, IL 60118

This drawing is copyrighted and is the sole property of GERALD L. HEINZ & ASSOCIATES, INC. Reproduction or use of this drawing in whole or in part and/or the information contained in it is forbidden without the written consent of GERALD L. HEINZ & ASSOCIATES, INC. Unauthorized use will be prosecuted to the fullest extent of the law.

DATE: 09/27/2018
JOB NO.: ED-2166
SCALE: 1"=20'
SHEET 1 OF 1